

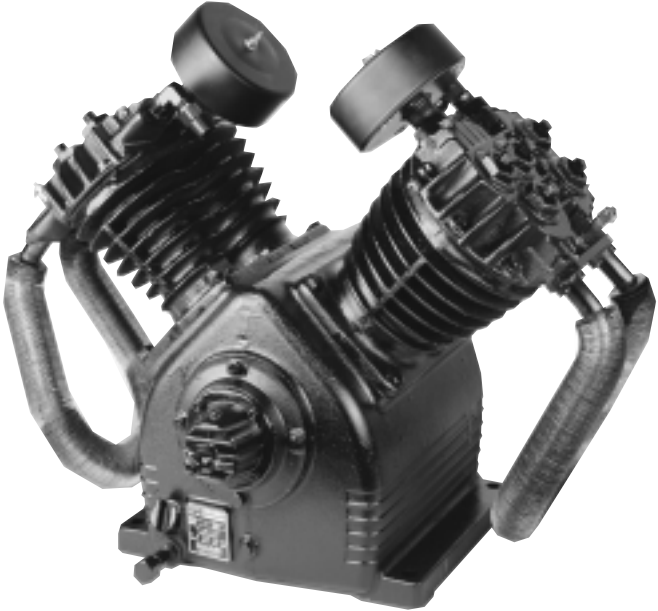

Distributed by: CENTRAIR Air Systems & Supplies 68 Hooper Rd., Unit 5, Barrie, ON L4N 8Z9
Phone: 705-722-5747 Fax: 705-722-5458 sales@centrair www.centrair.ca

447 Series Compressor Pump



Model No.	CPR	After-cooler tubes	Fly-wheel
447-4533	x	x	
447-523	x		x
447-4523	x		

NOTE: For installation and maintenance information refer to SB-30:001B

Specifications:

- Crankcase Capacity: 112 fluid ounces or 2.8 litres
- Minimum RPM: 500 with CPR
- Minimum RPM: 300 without CPR
- Maximum RPM: 900
- Maximum continuous duty working pressure: 175 psi

Warning – Check for proper oil level before using this equipment

Use Devair Premium Compressor Oil Part no. PR-20 for ambient temperatures below 90°F (32° C), or part no. PR-30 for ambient temperatures above 90° F (32° C)

Distributed by:

CENTRAIR Air Systems & Supplies
68 Hooper Rd., Unit 5, Barrie, ON L4N 8Z9
Phone: 705-722-5747 Fax: 705-722-5458
sales@centrair www.centrair.ca

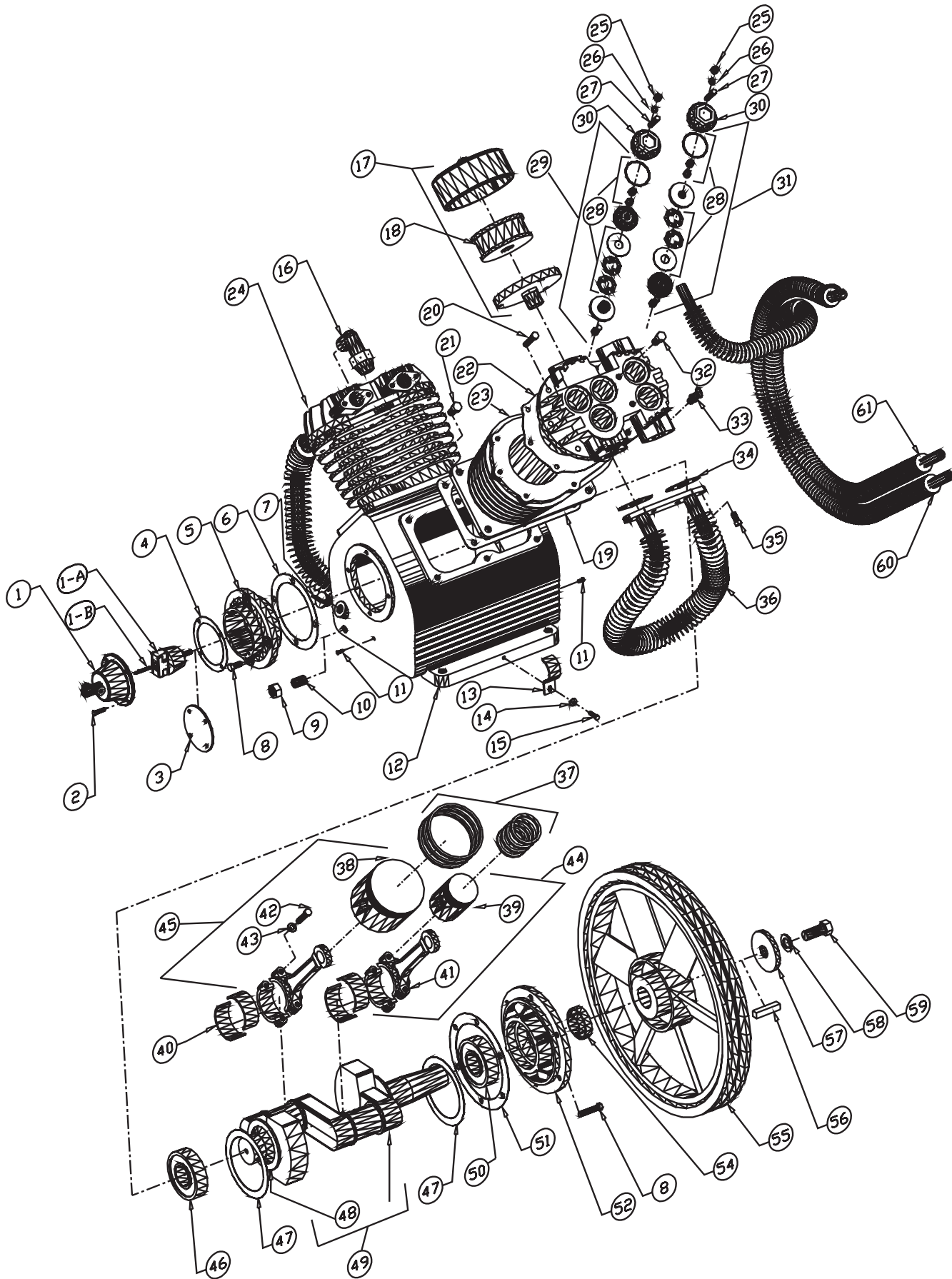

Ref. No.	Part No.	Description	Qty.	Ref. No.	Part No.	Description	Qty.
1	CPR-9400	CPR Assy.	1	30	445-840	Valve Plug	10
1a	CPR-9401	Flyweight Assy.	1	31	445-4205	Exhaust Valve Assy.	4
1b	CPR-9004	Valve Stem	1	32	SS-31	3/8" 16 x 2 1/2" Hex Screw	4
2	SS-10022	1/4"-20 Socket Screw	4	33	TIA-5075	75lb Safety Valve	2
3	445-9700	End Plate	1	34	445-196	Intercooler Gasket	4
4	445-144	Gasket	1	35	SS-9922	3/8" - 16 x 7/8" Socket Screw	8
5	445-136	Bearing Housing	1	36	447-330	Intercooler	2
6	445-12	End Plate Gasket	1	37	KK-9805	Ring Kit	2
7	NCB-303-1	Oil Filler Plug	1	38	445-412-1	Low Pressure Piston and Pin Assy.	2
8	SS-25	3/8" 16 x 1 Hex Screw	10	39	445-4112-1	High Pressure Piston and Pin Assy.	2
9	SS-9924	3/8" NPT Pipe Cap	1	40	445-474	Connecting Rod Bearing Insert (Std)	4
10	SS-2108	3/8" x 2 Nipple	1	41	445-4110-3	Rod and Cap Assy (Shrink Fit)	4
11	225-6	Screw	2	42	SS-9947	Connecting Rod Bolt	8
12	445-4	Crankcase	1	43	SS-9946	Lock Washer	8
13	SS-9941	Intercooler Bracket	2	44	445-9403	High Pressure Rod and Piston Assy.	2
14	SS-1523	1/4" Flat Washer	2	45	445-9402	Low Pressure Rod and Piston Assy.	2
15	SS-1	1/4"-20 x 1/2" Hex Screw	2	46	445-23	Ball Bearing	1
16	SS-01773	3 3/4" Compression Elbow	2	47	445-5-1	Oil Throw Ring	2
17	357-9401	Air Filter/Silencer Assy.	2	48	445-43	Oil Cup	2
18	357-9701	Air Filter Replacement Cartridge	2	49	445-450	Crankshaft and Oil Cup Assy.	1
19	445-327	Cylinder to Crankcase Gasket	2	50	SST-3001	Ball Bearing	1
20	SS-26	3/8"-16 x 1 1/4" Hex Bolt	14	51	445-13	End Plate Gasket	1
21	SS-48	1/2" - 13 x 1 Hex Head Cap Screw	12	52	445-9	End Plate	1
22	447-26	Head Gasket	2	54	445-111	Oil Seal	1
23	447-325	Cylinder	2	55	445-2-1	Flywheel	1
24	447-24	Cylinder Head	2	56	SS-10493	Square Key 1/2" x 2 1/2"	1
25	SS-7424-ZN	Cap Nut 3/8" x 14"	10	57	445-326	Flywheel Retaining Washer	1
26	SS-01767	Gasket	10	58	SS-1509	Lock Washer Medium 3/4"	1
27	SS-6045	Set Screw 3/8" - 16 x 1 1/2"	10	59	SS-6896	Hex Head Cap Screw 3/4" - 16 x 1"	1
28	VRK-247	Valve Repair Kit	2	60	CT-9479	Aftercooler Tube (outer)	1
29	445-4217	Intake Valve Assy.	6	61	CT-9480	Aftercooler Tube (inner)	1

Service Kits and Regular Maintenance Items

- VRK-247** Valve Repair Kit - Kit includes valve discs, jam and cap nuts, valve springs, set screws and valve gaskets (ref.# 28)
 Note: Two (2) kits required
- OK-447** Overhaul Kit - Kit includes gasket kit (GK-9403), ring kit (KK-9805), valve repair kit (VRK-247), bearing inserts (445-474) and an oil seal (445-111)
- GK-9403** Gasket Kit - Kit includes all gaskets (ref.# 4, 6, 19, 22, 26, 34, 51, 54 and all valve gaskets)
- MK-447** Maintenance Kit: Kit includes 3L of oil (PR-20) and two (2) air filters (357-9701)
- PR-20** Premium Compressor Oil - For operating temperatures below 90°F
- PR-30** Premium Compressor Oil - For operating temperatures above 90°F

CPR-9700 Centrifugal Pressure Release

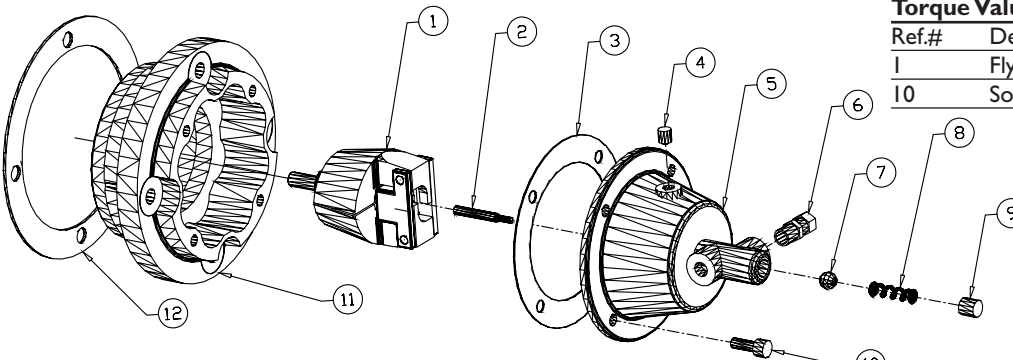

Ref.#	Description	In. lbs.	Ft. lbs.	Nm
1	Flyweight Assy.	.288	24	32.5
10	Socket Screw	96	8	10.8

1	CPR-9401	Plunger/Flyweight assy	5	CPR-9009	Valve/cup body	9	CPR-9000	Plug/guide
2	CPR-9004	Valve Stem	6	SS-8553	Compression Fitting	10	SS-10022	Socket Head Screw
3	445-144	Gasket	7	CPR-9007	Ball	11*	445-136	CPR Housing
4	CPR-9000-1	Plug	8	CPR-9006	Valve Spring	12*	445-12	Gasket

CPR Repair Kit: CPR-9010 includes # 2, 3, 7, 8, 9

*NOTE: these parts are required when converting a non-CPR pump to a CPR pump, and are not included in CPR-9700

Chart 1

Compressor Torque Values

(When SAE20 oil is used as a lubricant)

Ref. No.	Description	In.lbs.	Ft.lbs.	Nm
8	Small end plate	240	20	27.1
8	Large end plate	240	20	27.1
11	Oil ring retainer	144	12	16.2
42	Connecting rod	408	34	46
21	Cylinder to crankcase	564	47	63.7
20&32	Head bolts	360	30	40.6
59	Flywheel bolts	1860	155	210
30	Valve plug	1500	125	169
27	Valve set screw	180	15	20.3
25	Cap nuts	180	15	20.3
35	Intercooler Bolt	240	20	27.1
28	Valves	180	15	20.3

NOTE: Retorque head bolts, cylinder bolts, intercooler and end plates after first 10 hours of operation.

In.lbs. Inch Pounds
 Ft.lbs. Foot Pounds
 Nm Newton Meters

Chart 2

Honing Specifications

Cylinder	Std.Hone Dia	Skirt/Cyl.Dia clearance
Low pressure cylinder	4.5000/4.5005	.0065/.0085
High pressure cylinder	2.5000/2.5005	.0025/.0045

1. Cylinder must be within diametral tolerance at all points, out of round or taper must not exceed .005.
2. Hone, 20 min.to 35 max. micro inches of surface roughness.
3. De-burr the sharp corners at the top and bottom of the cylinder opening with a 1/64 to 1/32 x 30 degree chamfer.

Chart 3

Connecting Rod Insert Bearings

Insert	Crank Throw Dia	Part No.
Std.	2.2490/2.2485	445-474
0.02 Oversize	2.2290/2.2285	445-474-020

CAUTION: Pre-lubricate all crank throws and insert bearing surfaces to prevent compressor tie up during the first few minutes of operation. Pour some oil on the outside of the connecting rod and crank shoulders. Use the crankcase oil, DO NOT USE GREASE.

Compressor Dimensions

